



深圳市一众显示科技有限公司

SHEN ZHEN TEAM SOURCE DISPLAY TECH. CO, LTD.

TFT-LCD Module Specification

Module NO.: TST013QVHG-06C

Version: V1.0

APPROVAL FOR SPECIFICATION

APPROVAL FOR SAMPLE

For Customer' s Acceptance:	
Approved by	Comment

Team Source Display:		
Presented by	Reviewed by	Organized by

Version No.	Date	Content	Remark
V1.0	2021-10-27	Initial Release	

CONTENTS

1 GENERAL CHARACTERISTICS..... - 3 -

2 PRODUCT DRAWINGS..... - 4 -

3 INTERFACE DESCRIPTION..... - 5 -

 3.1 LCM INTERFACE DESCRIPTION..... - 5 -

4 TIMING CHARACTERISTICS..... - 6 -

5 ABSOLUTE MAXIMUM RATINGS..... - 14 -

6 ELECTRICAL CHARACTERISTICS..... - 14 -

7 BACKLIGHT CHARACTERISTICS..... - 14 -

8 LCD OPTICAL SPECIFICATIONS..... - 15 -

9 TOUCH PANEL SPECIFICATIONS..... - 17 -

 9.1 MECHANICAL CHARACTERISTICS..... - 17 -

 9.2 ELECTRICAL CHARACTERISTICS..... - 17 -

 9.3 INTERFACE TIMING CHARACTERISTICS..... - 17 -

10 RELIABILITY TEST..... - 18 -

11 IMAGE STICKING..... - 18 -

 11.1 WHAT IS IMAGE STICKING?..... - 18 -

 11.2 WHAT CAUSE IMAGE STICKING?..... - 19 -

 11.3 HOW TO AVOID IMAGE STICKING?..... - 19 -

 11.4 HOW TO FIX THE IMAGE STICKING?..... - 19 -

 11.5 IS IMAGE STICKING COVERED BY TSD WARRANTY?..... - 20 -

12 SUGGESTIONS FOR USING LCD MODULES..... - 20 -

 12.1 HANDLING OF LCM..... - 20 -

 12.2 STORAGE..... - 21 -

13 LIMITED WARRANTY..... - 21 -

 13.1 - 21 -

 13.2 - 21 -

 13.3 - 21 -

1 General Characteristics

ITEM	Specification	Unit
LCD Type	a-Si TFT, Transmissive, Normally Black, IPS	-
LCD Size	1.28	inch
Resolution (W x H)	240x (RGB) ×240	pixel
LCM size	35.6(H) x 37.74(V) x 1.6(D)	mm
Active Area	32.4 (H) x 32.4 (V)	mm
Pixel Pitch	0.135(H)x 0.135(V)	mm
Viewing Direction	ALL o'clock	-
Color Depth	65/262K	-
Pixel Arrangement	RGB-stripe	-
Backlight Type	2 LEDs, 20mA	-
Surface Treatment	-	-
Interface Type	3 wire 2 data line SPI	-
Input Voltage	2.8	V
With/Without TP	With CTP(ST1624i)	-
Weight	TBD	g

Note 1: RoHS compliant

Note 2: LCM weight tolerance: ± 5%.

2 Product drawings

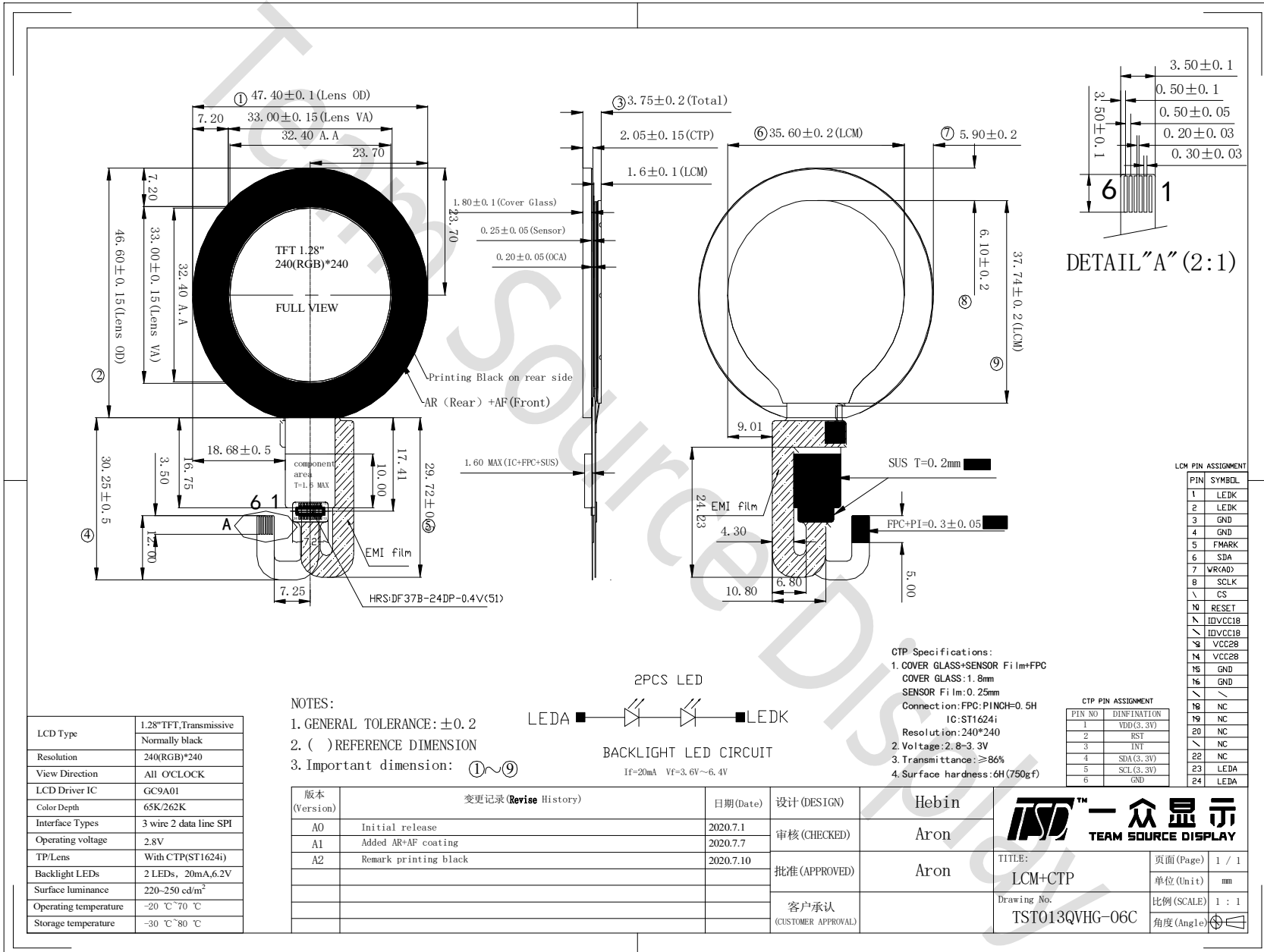

TITLE: LCM+CTP
Drawing No. TST013QVHG-06C

页面 (Page) 1 / 1
单位 (Unit) mm
比例 (SCALE) 1 : 1
角度 (Angle) ④

3 Interface description

3.1 LCM interface description

PIN NO.	Symbol	description
1	LEDK	Backlight K Cathode input pin.
2	LEDK	Backlight K Cathode input pin.
3	GND	System Ground. (0V)
4	GND	System Ground. (0V)
5	FMARK	Tearing effect output pin
6	SDA	SPI data input/ouput singal
7	WR(A0)	SPI data input singal
8	SCLK	SPI colck singal
9	CS	Chip selection singal
10	RESET	Reset input singal
11~12	IOVCC18	Low voltage power supply for interface logic circuits
13~14	VCC28	Power supply +2.8V
15~16	GND	System Ground. (0V)
17~22	NC	Not connection
23~24	LEDA	Backlight A Aothod input pin.

4 Timing Characteristics

4.1.9. Write Cycle Sequence

The write mode of the interface means that host writes commands or data to GC9A01. The 3-lines serial data packet contains a data/command select bit (D/CX) and a transmission byte. If the D/CX bit is “low”, the transmission byte is interpreted as a command byte. If the D/CX bit is “high”, the transmission byte is stored as the display data RAM(Memory write command),or command register as parameter.

Any instruction can be sent in any order to GC9A01 and the MSB is transmitted first. The serial interface is initialized when CSX is high status. In this state, SCL clock pulse and SDA data are no effect. A falling edge on CSX enables the serial interface and indicates the start of data transmission. See the detailed data format for 3-/4-line serial interface.

Figure 10.

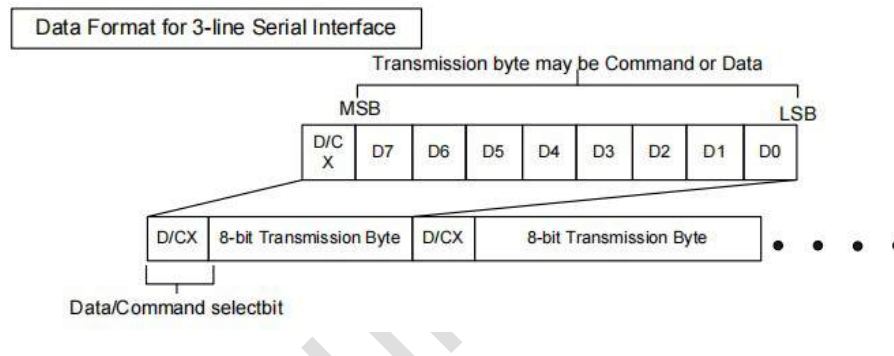
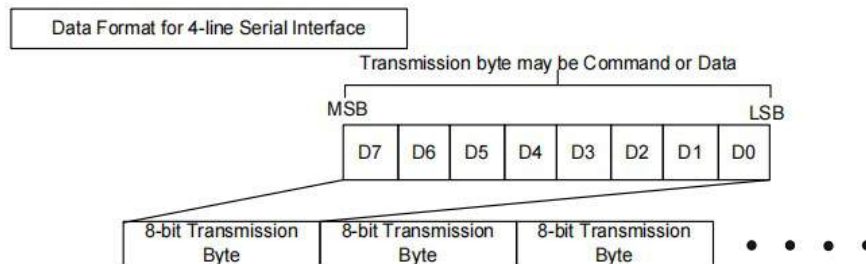

Figure 11.



Host processor drives the CSX pin to low and starts by setting the D/CX bit on SDA. The bit is read by GC9A01 on the first rising edge of SCL signal. On the next falling edge of SCL, the MSB data bit (D7) is set on SDA by the host. On the next falling edge of SCL, the next bit (D6) is set on SDA. If the optional D/CX signal is used, a byte is eight read cycle width. The 3/4-line serial interface writes sequence described in the figure as below.

Figure 12.

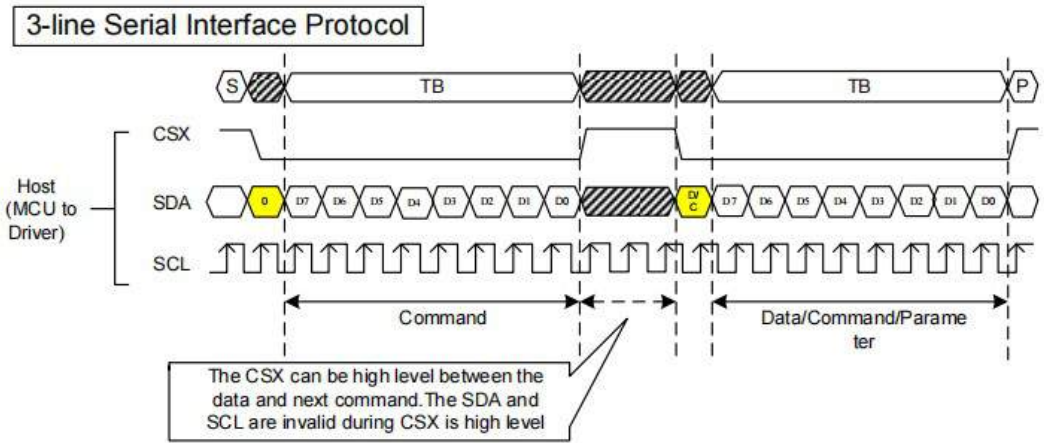
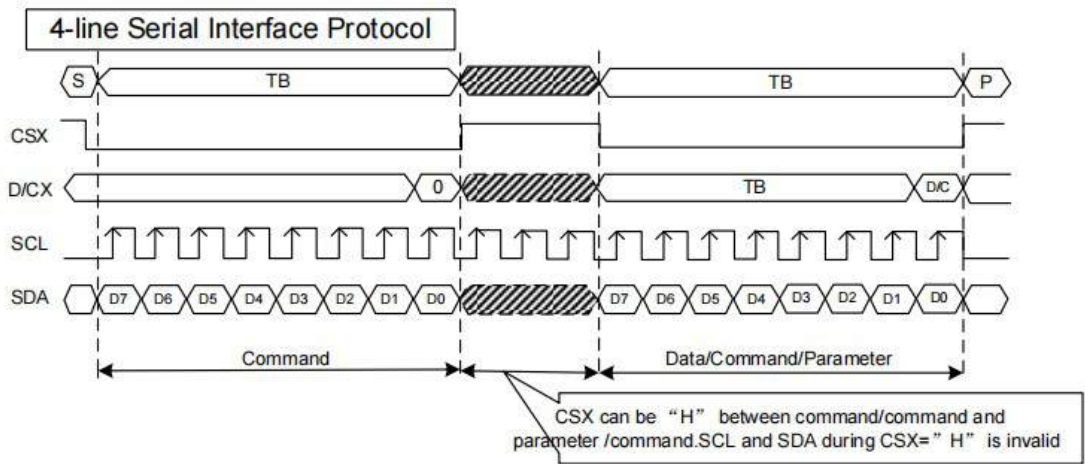

Figure 13.



4.1.10. Read Cycle Sequence

The read mode of interface means that the host reads register's parameter from GC9A01. The host has to send a command (Read ID or register command) and then the following byte is transmitted in the opposite direction. GC9A01 latches the SDA (input data) at the rising edges of SCL (serial clock), and then shifts SDA (output data) at falling edges of SCL (serial clock). After the read status command has been sent, the SDA line must be set to tri-state and no later than at the falling edge of SCL of the last bit. The read mode has three types of transmitted command data (8-/24-/32-bit) according command code.

Figure 14.

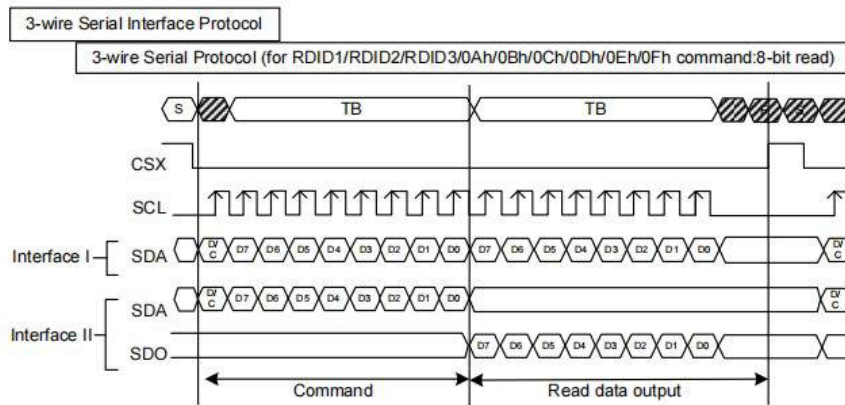

Figure 15.

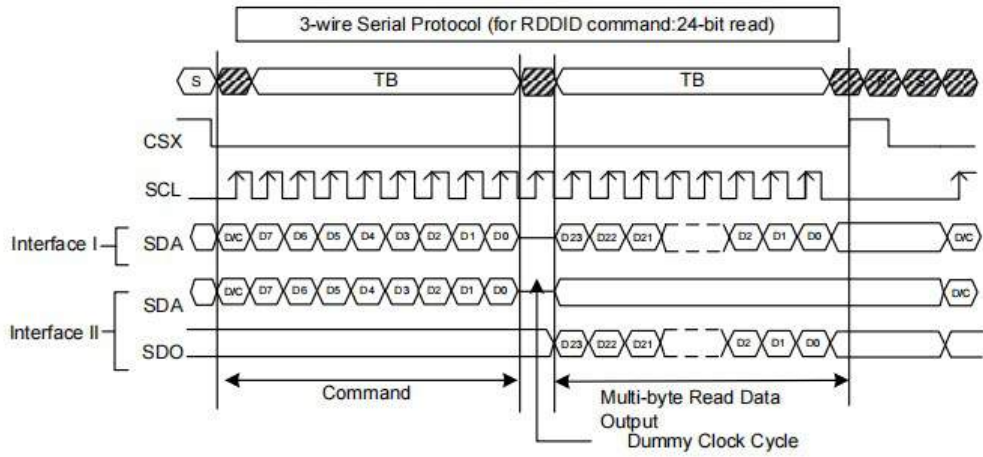
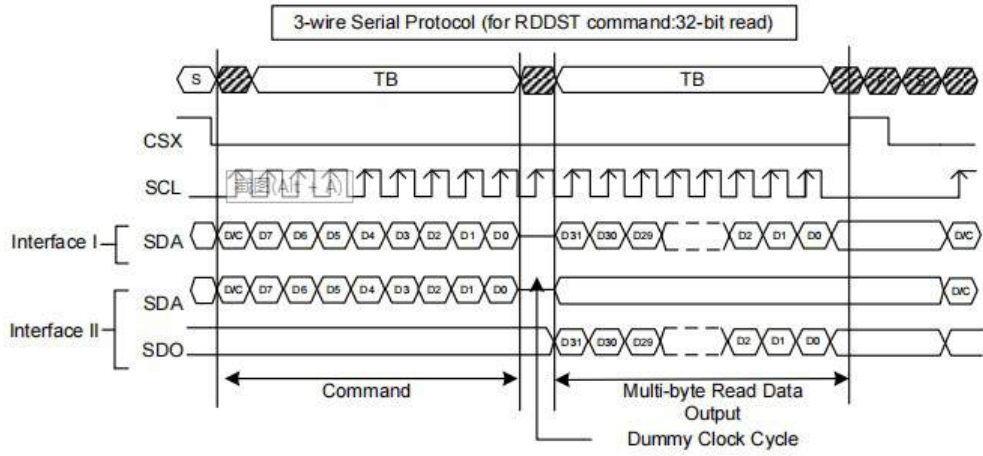

Figure 16.



Team Source Display

Figure 17.

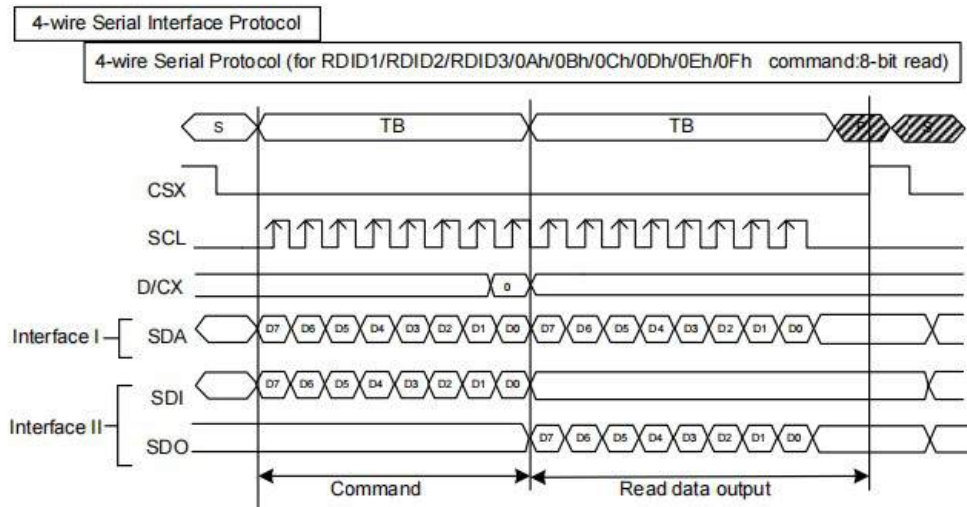

Figure 18.

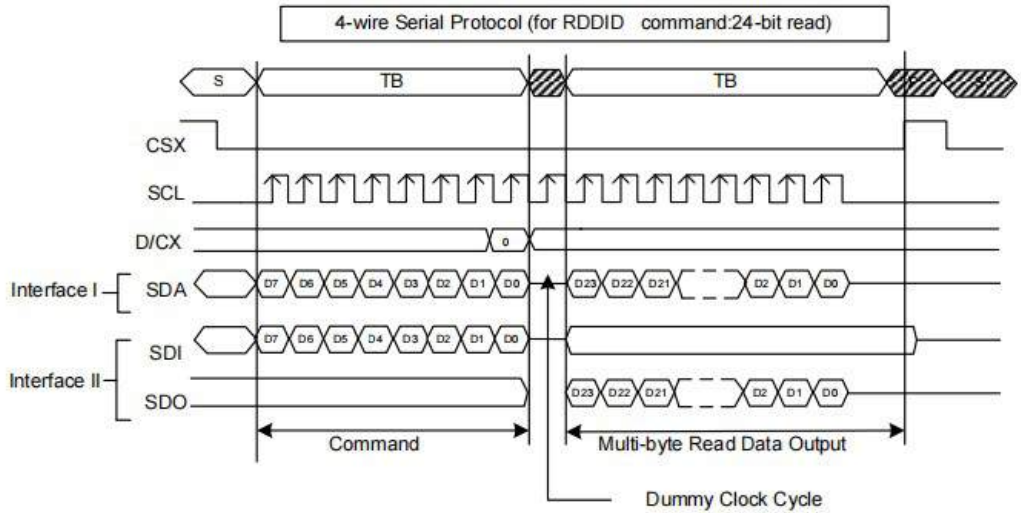
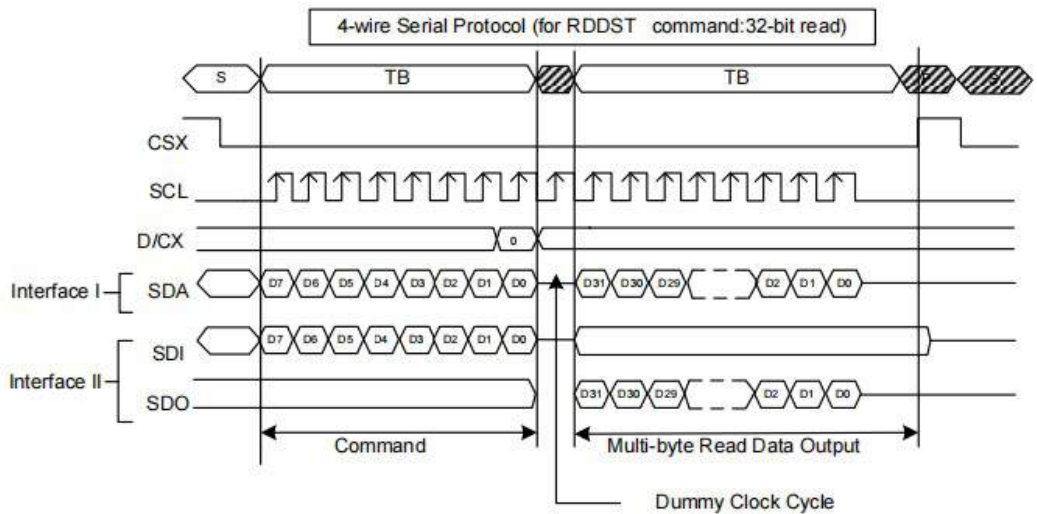

Figure 19.



4.1.11. Data Transfer Break and Recovery

If there is a break in data transmission by RESX pulse, while transferring a command or multiple parameter command data, before Bit D0 of the byte has been completed, then the driver will reject the previous bits and have reset the interface such that it will be ready to receive command data again when the chip select pin (CSX) is activated after RESX have been high state.

Figure 20.

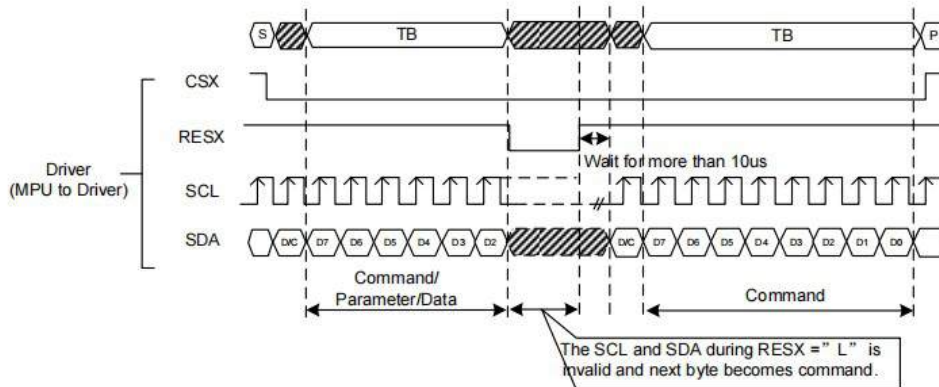

If there is a break in data transmission by CSX pulse, while transferring a command or frame memory data or multiple parameter command data, before Bit D0 of the byte has been completed, then the driver will reject the previous bits and have reset the interface such that it will be ready to receive the same byte re-transmitted when the chip select pin (CSX) is next activated.

Figure 21.

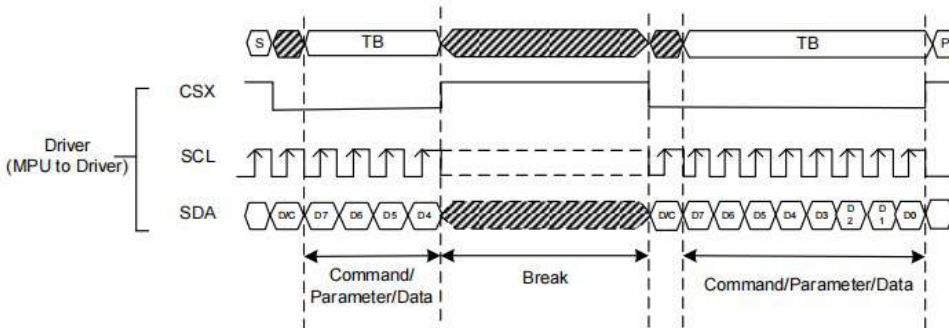

If a two or more parameter command is being sent and a break occurs while sending any parameter before the last one and if the host then sends a new command rather than continue to send the remained parameters that was interrupted, then the parameters which had been successfully sent are stored and the parameter where the break occurred is rejected. The interface is ready to receive next byte as shown below.

Figure 22.

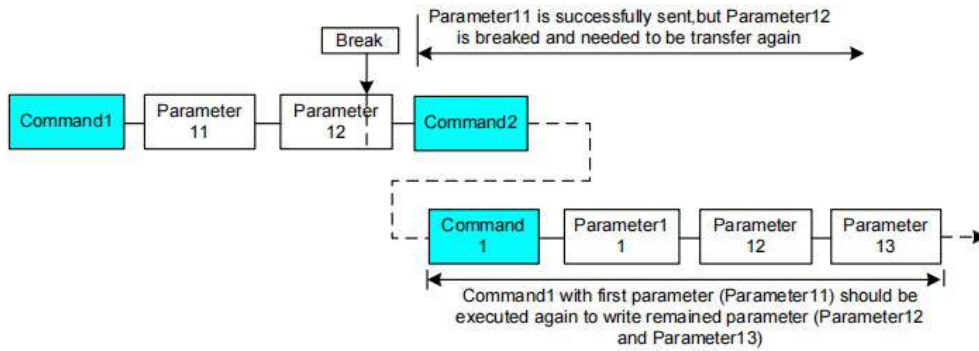

If a two or more parameter command is being sent and a break occurs by the other command before the last one is sent, then the parameters which had been successfully sent are stored and the other parameter of that command remains previous value.

Figure 23.

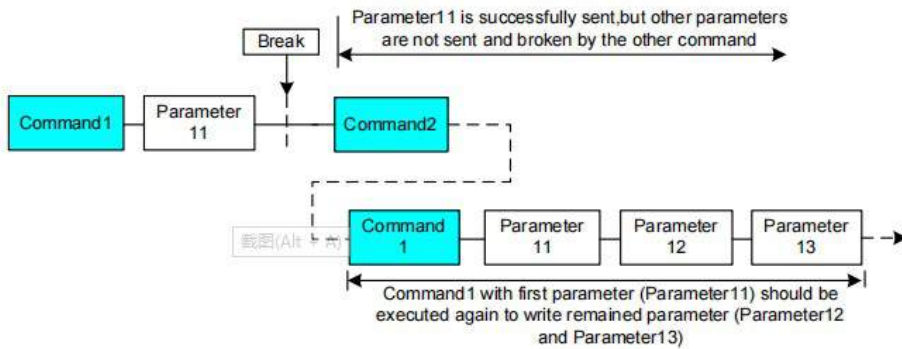

7.3.4. Display Serial Interface Timing Characteristics (4-line SPI system)

Figure98.

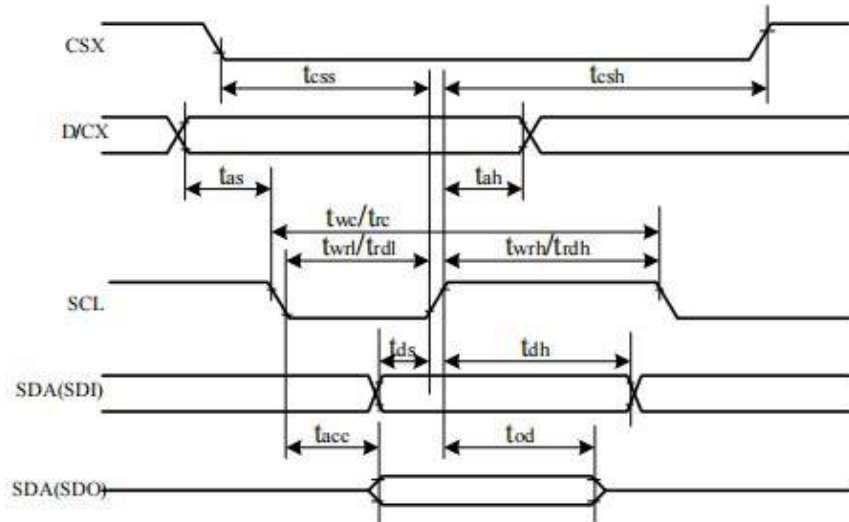
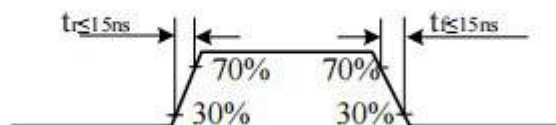

Table48.

Signal	Symbol	Parameter	min	max	Unit	Description
CSX	t_{ess}	Chip select time (Write)	20	-	ns	
	t_{esh}	Chip select hold time (Read)	40	-	ns	
SCL	t_{wc}	Serial Clock Cycle (Write)	10	-	ns	
	t_{wrh}	SCL "H" Pulse Width (Write)	5	-	ns	
	t_{wrl}	SCL "L" Pulse Width (Write)	5	-	ns	
	t_{rc}	Serial Clock Cycle (Read)	150	-	ns	
	t_{rdh}	SCL "H" Pulse Width (Read)	60	-	ns	
	t_{rdl}	SCL "L" Pulse Width (Read)	60	-	ns	
D/CX	t_{as}	D/CX setup time	10	-	ns	
	t_{ah}	D/CX hold time (Write/Read)	10	-	ns	
SDA/SDI (Input)	t_{ds}	Data setup time (Write)	5	-	ns	
	t_{dh}	Data hold time (Write)	5	-	ns	
SDA/SD0 (Output)	t_{acc}	Access time (Read)	10	-	ns	

Note: $T_a = 25\text{ }^\circ\text{C}$, $IOVCC=1.65V$ to $3.3V$, $VCI=2.5V$ to $3.3V$, $AGND=VSS=0V$

Figure99.



5 Absolute Maximum Ratings

PARAMETER	SYMBOL	MIN	MAX	UNIT
Supply Voltage (Analog)	VDD~GND	-0.3	4.0	V
Logic signal voltage(I/O)	IOVDD~GND	-0.3	4.0	V
Operating Temperature	TOP	-20	70	° C
Storage Temperature	TST	-30	80	° C
Humidity	RH	-	90%(Max 60° C)	RH

6 Electrical Characteristics

PARAMETER	SYMBOL	MIN	TYP	MAX	UNIT
Analog operating voltage	VDD	2.4	2.8	3.3	V
Logic operating voltage	VDDI	1.65	1.8	VDD	
Input Voltage ' H ' level	VIH	0.7VDDI	-	VDDI	
Input Voltage ' L ' level	VIL	GND	-	0.3VDDI	
Output Voltage ' H ' level	VOH	VDDI-0.4	-	VDDI	
Output Voltage ' L ' level	VOL	GND	-	GND+0.4	

7 Backlight Characteristics

ITEM	SYMBOL	MIN	TYP	MAX	UNIT
Voltage for LED backlight	V _f	-	3.6	-	V
Current for LED backlight	I _f	-	20	-	mA
Power consumption	W _{bl}	-	72	-	mW
Uniformity	Avg	80	-	-	%
LED Life Time	-	20000	30000	-	Hrs

Note:

- 1.The LED life time is defined as the module brightness decrease to 50% original brightness at Ta=25°C, 60%RH ±5 %.
2. The life time of LED will be reduced if LED is driven by high current, high ambient temperature and humidity conditions.
3. Typical operating life time is an estimated data.
4. Permanent damage to the device may occur if maximum values are exceeded or reverse voltage is loaded .Functional operation should be restricted to the conditions described under normal operating conditions.

8 LCD Optical specifications

Item	Symbol	Condition	Specification			Unit	Remark
			Min	Typ	Max		
Response time (By Quick)	Tr+Tf	-	-	30	35	ms	Note 2
Contrast ratio	CR	-	-	1100	-	-	Note 3
Surface luminance	Lv	$\theta=0^\circ$	200	230	-	cd/m ²	Note 4
Luminance uniformity	Yu	$\theta=0^\circ$	80	-	-	%	Note 6
NTSC	-	$\theta=0^\circ$	45	50	-	%	Note 6
Viewing angle	Top	$CR \geq 10$	80	85	-	Deg.	Note 7
	Bottom	$CR \geq 10$	80	85	-		
	Left	$CR \geq 10$	80	85	-		
	Right	$CR \geq 10$	80	85	-		
CIE(x,y) chromaticity	Wx	$\theta=0^\circ$	Typ -0.03	0.310	Typ +0.03		Note 5
	Wy			0.350			
	Rx			0.630			
	Ry			0.350			
	Gx			0.350			
	Gy			0.620			
	Bx			0.150			
	By			0.080			

Note 1: Ambient temperature = 25°C.

Note 2: Definition of response time:

The output signals of TRD-100 are measured when the input signals are changed to “White” (falling time) and from “White” to “Black” (rising time), respectively. The interval is between the 10% and 90% of amplitudes. Refer to figure as below.

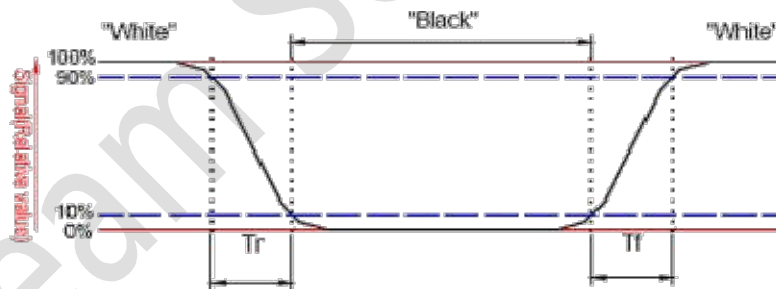

Note 3: Definition of contrast ratio:

Contrast ratio is calculated by the following formula.

$$\text{Contrast ratio (CR)} = \frac{\text{Brightness on the "white" state}}{\text{Brightness on the "black" state}}$$

Measured at the center area of the LCD.

Note 4: Definition of surface luminance

Surface luminance is the luminance with all pixels displaying white

Note 5: For contrast ratio, Surface Luminance, Luminance uniformity and CIE, the testing data is based on TOPCON's BM-7 photo detector or compatible.

Size : $S \leq 4.3''$ (see Figure A B)

H,V : Active area

Light spot size=7.7mm (BM-7)50cm distance or compatible distance from the LCD surface to detector lens.

test spot position : see Figure B.

measurement instrument : TOPCON' s luminance meter BM-7 or compatible.

Size : $4.3 < S \leq 12.3''$ (see Figure A C)

H,V : Active area

Light spot size=7.7mm (BM-7)50cm distance or compatible distance from the LCD surface to detector lens.

test spot position : see Figure C.

measurement instrument : TOPCON' s luminance meter BM-7 or compatible.

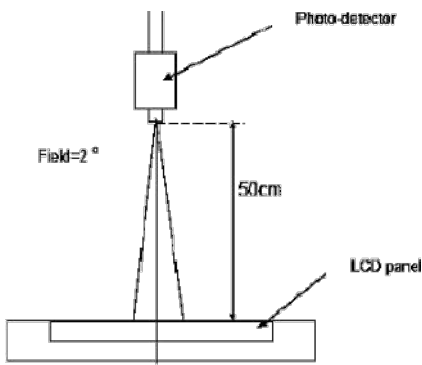

Figure A

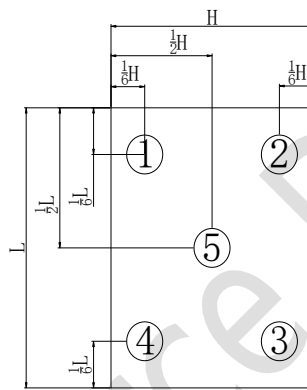

Figure B

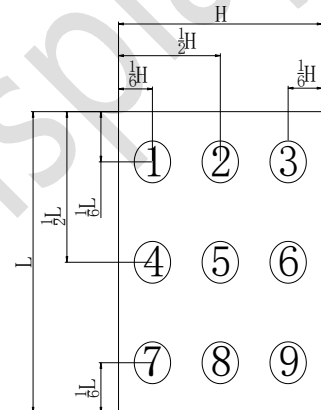

Figure C

Note 6:Definition of Luminance Uniformity

Active area is divided into 5 or 9 measuring areas,Every measuring point is placed at the center of each measuring area

Bmax: The measured maximum luminance of all measurement position.

Bmin: The measured minimum luminance of all measurement position.

Luminance Uniformity (Yu) = (Bmin/Bmax)x100%

Note 7: Definition of viewing angle

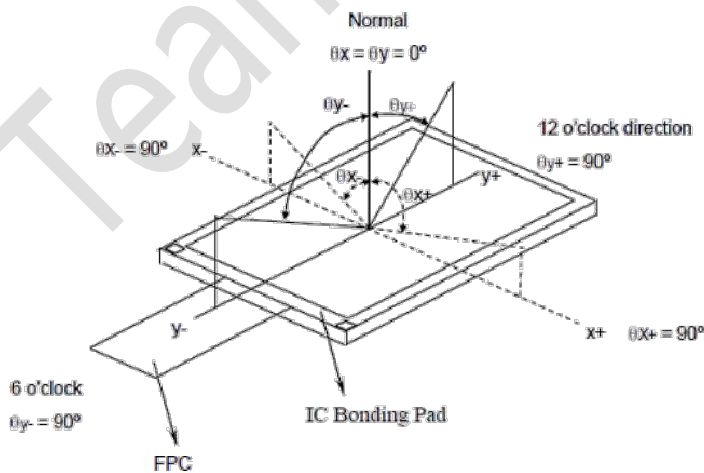

9 Touch Panel specifications

9.1 Mechanical characteristics

DESCRIPTION	INL SPECIFICATION	REMARK
Touch Panel Size	1.28	
Outline Dimension (OD)	47.4(H) x 46.6(V) mm	Cover Lens Outline
Product Thickness	2.05mm(±0.1)	
Glass Thickness	1.8mm	
Ink View Area	33x33mm	
Input Method	5 Fingers	
Activation Force	Touch	
Surface Hardness	≥6H	

9.2 Electrical characteristics

DESCRIPTION		SPECIFICATION
Operating Voltage		DC 2.8~33V
Power Consumption (IDD)	Active Mode	12~4.5mA
	Sleep Mode	TBD
Interface		I ² C
Controller IC		ST1624i
I ² C address		-
Resolution		240*240

9.3 Interface timing characteristics

PARAMETER	MIN	MAX	UNIT
SCL Frequency	-	400K	Hz
Bus Free Time Between a STOP and START Condition	1.3	-	uS
Hold Time (repeated) START Condition	0.6	-	uS
Data Setup Time	100	-	nS
Setup Time for Repeated START Condition	0.6	-	uS
Setup Time for STOP Condition	0.6	-	uS

10 RELIABILITY TEST

NO.	TEST ITEM	TEST CONDITION	INSPECTION AFTER TEST
1	High Temperature Storage	80±2°C/96 hours	Inspection after 2~4 hours storage at room temperature and humidity. The condensation is not accepted. The sample shall be free from defects: 1. Air bubble in the LCD 2. Seal leak 3. Non-display 4. Missing segments 5. Glass crack
2	Low Temperature Storage	-30±2°C/96 hours	
3	High Temperature Operating	70±2°C/96 hours	
4	Low Temperature Operating	-20±2°C/96 hours	
5	Temperature Cycle	-30±2°C ~ 25~ 80± 2°C × 10 cycles (30 min.) (5min.) (30min.)	
6	Damp Proof Test	60°C ±5°C × 90%RH/96 hours	
7	Vibration Test	Frequency 10Hz~55Hz Stroke: 1.5mm Sweep: 10Hz~150 Hz~10Hz 2 hours For each direction of X, Y, Z	
8	Packing Drop Test	Height: 50 cm 1 corner, concrete floor	
9	Electrostatic Discharge Test	C=150pF, R=330 Ω Air: ±8KV 150pF/330Ω 30 times Contact: ±4KV,20 times	
10	Image Sticking	25°C, 60%RH (ref. to Remark(1))	

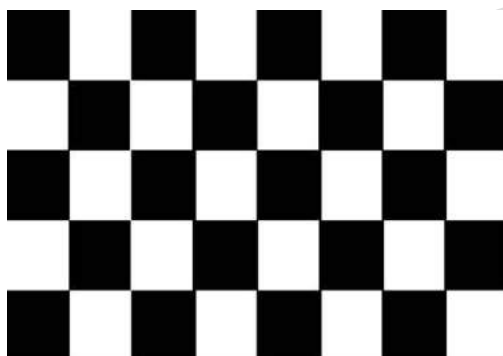

5*8 chess pattern

11 Image Sticking

11.1 What is image sticking?

If you remain a fixed image on LCD Display for a long period of time, you may experience a phenomenon called Image Sticking. Image Sticking - sometimes also called "image retention" or "ghosting" - is a phenomenon where a faint outline of a previously displayed image remains visible on the screen when the image is changed. It can occur at variable levels of intensity depending on the specific image makeup, as well as the amount of time the core image elements are allowed to remain unchanged on the screen. In POS applications, for example, a button menu which remains fixed, or in which the "frame" elements (core image) remain fixed and the buttons

may change, may be susceptible to image sticking. It is important to note that if the screen is used exclusively for this application, the user may never notice this phenomenon since the screen never displays other content. It is only when an image other than the “retained” image is shown on the screen that this issue becomes evident. Image sticking is different than the “burn-in” effect commonly associated with phosphor based devices.

11.2 What cause image sticking?

Image sticking is an intrinsic behavior of LCD displays due to the susceptibility to polarization of the interior materials (liquid crystals) when used under static, charged conditions (continuously displaying the same image). The individual liquid crystals in an LCD panel have unique electrical properties. Displaying a fixed pattern - such as the POS menu described above – over prolonged periods can cause a parasitic charge build-up (polarization) within the liquid crystals which affects the crystals’ optical properties and ultimately prevents the liquid crystal from returning to its normal, relaxed state when the pattern is finally changed. This effect takes place at a cellular level within the LCD, and the effect can cause charged crystal alignment at the bottom or top of a crystal cell in the “z” axis, or even crystal migration to the edges of a cell, again based on their polarity. These conditions can cause image sticking over an entire area, or at boundaries of distinct color change respectively. In either case, when the liquid crystals in the pixels and sub-pixels utilized to display the static image are polarized such that they can not return fully to their “relaxed” state upon deactivation, the result is a faint, visible, retained image on the panel upon presentation of a new, different image. The actual rate of image retention depends on variation factors such as the specific image, how long it is displayed unchanged, the temperature within the panel and even the specific panel brand due to manufacturing differences amongst panel manufacturers.

11.3 How to avoid image sticking?

- Try not to operate the LCD with a “fixed” image on the screen for more than 2 hours.
- If you are operating the monitor in an elevated temperature environment and with a displayed image which is contrary to the recommendations in “For Software Developers” below, image stick can occur in as little as 30 minutes. Adjust your screen saver settings accordingly.
- Power down the unit during prolonged periods of inactivity such as the hours a store is closed or a shift during which the piece of equipment isn’t used.
- Use a screensaver with a black or medium gray background that is automatically set to come on if the device is inactive for more than 5-10 minutes.
- Avoid placing the monitor in poorly ventilated areas or in areas that will create excess heat around the monitor for software developers.
- In defining the icons, buttons, or windows in the screen, try to utilize block patterns instead of distinct lines as borders for dividing the display into distinct areas.
- If it is necessary to display a static image, try to use colors that are symmetric to the middle grey level at the boundary of two different colors, and slightly shift the borders line once in a while.
- Try to utilize medium gray hues for those areas that will have prolonged display times or remain static as other menu elements change.

11.4 How to fix the image sticking?

Unlike the usually irreversible “burn-in” effects commonly associated with direct view phosphor display devices such as CRTs, an image retained on an LCD display can be reversed – often to a point of total invisibility. However, the severity of the underlying causes (as described above) of the image retained on a specific display, as well as the variation factors under which the retained image was created, will dictate the final level of retention reversal.

One way to erase a retained image on a panel is to run the screen (monitor "on") in an "all black" pattern for 4-6 hours. It is also helpful to do this in an elevated temperature environment of approximately 35° to 50°C. Again, utilizing a dynamic screen saver with an all black background during prolonged idle display periods is a good way to avoid image retention issues.

11.5 Is image sticking covered by TSD warranty?

Image sticking is a phenomenon inherent to LCD Display technology itself, and as such, the occurrence of this "ghosting" effect is considered normal operation by the manufacturers of the LCD display modules which are integrated into today's monitor solutions. TSD does not warrant any display against the occurrence of image sticking. We strongly advise that you follow the operating recommendations listed above to avoid the occurrence of this phenomenon.

12 Suggestions for using LCD modules

12.1 Handling of LCM

1. The LCD screen is made of glass. Don't give excessive external shock, or drop from a high place.
2. If the LCD screen is damaged and the liquid crystal leaks out, do not lick and swallow. When the liquid is attach to your hand, skin, cloth etc, wash it off by using soap and water thoroughly and immediately.
3. Don't apply excessive force on the surface of the LCM.
4. If the surface is contaminated, clean it with soft cloth. If the LCM is severely contaminated, use Isopropyl alcohol/Ethyl alcohol to clean. Other solvents may damage the polarizer. The following solvents is especially prohibited: water , ketone Aromatic solvents etc.
5. Exercise care to minimize corrosion of the electrode. Corrosion of the electrodes is accelerated by water droplets, moisture condensation or a current flow in a high-humidity environment.
6. Install the LCD Module by using the mounting holes. When mounting the LCD module make sure it is free of twisting, warping and distortion. In particular, do not forcibly pull or bend the I/O cable or the backlight cable.
7. Don't disassemble the LCM.
8. To prevent destruction of the elements by static electricity, be careful to maintain an optimum work environment.
 - Be sure to ground the body when handling the LCD modules.
 - Tools required for assembling, such as soldering irons, must be properly grounded.
 - To reduce the amount of static electricity generated, do not conduct assembling and other work under dry conditions.
 - The LCD module is coated with a film to protect the display surface. Exercise care when peeling off this protective film since static electricity may be generated.
9. Do not alter, modify or change the the shape of the tab on the metal frame.
10. Do not make extra holes on the printed circuit board, modify its shape or change the positions of components to be attached.
11. Do not damage or modify the pattern writing on the printed circuit board.
12. Absolutely do not modify the zebra rubber strip (conductive rubber) or heat seal connector
13. Except for soldering the interface, do not make any alterations or modifications with a soldering iron.
14. Do not drop, bend or twist LCM.

12.2 Storage

1. Store in an ambient temperature of 5 to 45 °C, and in a relative humidity of 40% to 60%. Don't expose to sunlight or fluorescent light.
2. Storage in a clean environment, free from dust, active gas, and solvent.
3. Store in antistatic container.

13 Limited Warranty

13.1

Our warranty liability is limited to repair and/or replacement. We will not be responsible for any consequential loss.

13.2

If possible, we suggest customer to use up all LCD modules as soon as possible. If the LCD module storage time over twelve months, we suggest to recheck it before being used.

13.3

Any product issues must be feedback to TSD within twelve months since delivery, otherwise, we will not be responsible for the subsequent or consequential events.

